

Power Grid and Energy Management System

Lezione 15

5 maggio 2015

Ing. Chiara Foglietta
foglietta.chiara@gmail.com

Sistemi di Controllo per l'Automazione Industriale
Ingegneria Gestionale
A.A. 2014 - 2015
Università degli Studi di Cassino e del Lazio Meridionale





Agenda

Lezione 15

Chiara Foglietta

Definition of Power Grid

Historical Notes

Structure of the Power System

Generating Units

Substations

Transmission and Distribution Network

Energy Management System

State Estimation

Automatic Generation Control

Definition of Power Grid

Historical Notes

Structure of the Power System

Generating Units

Substations

Transmission and Distribution Network

Energy Management System

State Estimation

Automatic Generation Control



Purpose of this lesson

Lezione 15

Chiara Foglietta

Definition of Power Grid

Historical Notes

Structure of the Power System

Generating Units

Substations

Transmission and Distribution Network

Energy Management System

State Estimation

Automatic Generation Control

The aim of this lesson is:

1. understand the history of power grids and their evolutions
2. detect the main components of electrical grids
3. see the Energy Management System functionalities
4. get confidence with state estimation and automatic generation control modules



Reading Materials

Lezione 15

Chiara Foglietta

Definition of Power
Grid

Historical Notes

Structure of the Power
System

Generating Units

Substations

Transmission and
Distribution Network

Energy Management
System

State Estimation

Automatic Generation
Control

<http://burnanenergyjournal.com/the-electricity-grid-a-history>

http://en.wikipedia.org/wiki/Electricity_sector_in_Italy

Power System State Estimation: Theory and Implementation,
by Ali Abur, Antonio Gómez Expósito

Power System Dynamics: Stability and Control, by Jan
Machowski, Janusz Bialek, Dr James Bumby

Lezione 15

Chiara Foglietta

4

Definition of Power
Grid

Historical Notes

Structure of the Power
System

Generating Units

Substations

Transmission and
Distribution Network

Energy Management
System

State Estimation

Automatic Generation
Control

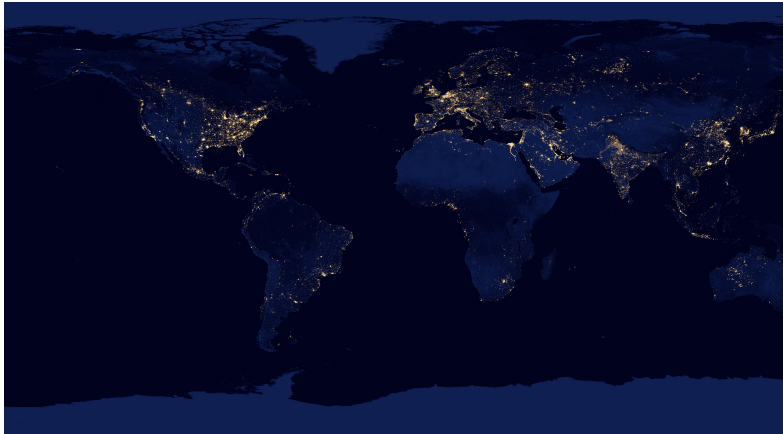

U.S. National Aeronautics and Space Administration (NASA);
<http://earthobservatory.nasa.gov/NaturalHazards/view.php?id=79765>; Latest
access: March 2013



What is Power Grid?

Lezione 15

Chiara Foglietta

Definition of Power Grid

5

Historical Notes

Structure of the Power System

Generating Units

Substations

Transmission and Distribution Network

Energy Management System

State Estimation

Automatic Generation Control

The electric power grid can be defined as the entire apparatus of wires and machines that connects the sources of electricity (i.e., the power plants) with customers.

When most people talk about the “grid”, they are usually referring to the electrical transmission system, which moves the electricity from power plants to substations located close to large groups of users. However, the grid also encompasses the distribution facilities that move the electricity from the sub-stations to the individual users.



Historical Notes I

Lezione 15

Chiara Foglietta

Definition of Power Grid

Historical Notes

Structure of the Power System

Generating Units

Substations

Transmission and Distribution Network

Energy Management System

State Estimation

Automatic Generation Control

6

1882: The Pearl Street Station in New York City was the first of these complete systems, connecting a 100-volt generator that burned coal to power a few hundred lamps in the neighbourhood. In a direct current, the electrons flow in a complete circuit, from the generator, through wires and devices, and back to the generator.

1888: William Stanley, Jr. built the first generator that used alternating current (AC). Instead of electricity flowing in one direction, the flow switches its direction, back and forth. Westinghouse Corporation bought the patent rights to Tesla's AC equipment.



Historical Notes II

Lezione 15

Chiara Foglietta

Definition of Power Grid

Historical Notes

Structure of the Power System

Generating Units

Substations

Transmission and Distribution Network

Energy Management System

State Estimation

Automatic Generation Control

7

1930s: Regulated electric utilities became well-established, providing all three major aspects of electricity, the power plants, transmission lines, and distribution. This type of electricity system, a regulated monopoly, is called a vertically-integrated utility

1978: The Public Utilities Regulatory Policies Act was passed, making it possible for power plants owned by non-utilities to sell electricity too, opening the door to privatization, demonstrated that traditional vertically integrated electric utilities were not the only source of reliable power.

1992: The Federal government stepped in and created rules to force open access to the lines (Energy Policy Act-EPACT), and set the stage for Independent System Operators, not-for-profit entities that managed the transmission of electricity in different regions.



Historical Notes III

Lezione 15

Chiara Foglietta

Definition of Power Grid

Historical Notes

Structure of the Power System

Generating Units

Substations

Transmission and Distribution Network

Energy Management System

State Estimation

Automatic Generation Control

8

1999: Federal Energy Regulatory Commission's (FERC's) issued Order 2000 calling for the creation of regional transmission organizations (RTOs), independent entities that will control and operate the transmission grid free of any discriminatory practices.

Today: From the very beginning of electricity in America, systems were varied and regionally-adapted, and it is no different today. Some states have their own independent electricity grid operators, like California and Texas. Other states are part of regional operators, like the Midwest Independent System Operator or the New England Independent System Operator. Not all regions use a system operator, and there are still thousands of municipalities that provide all aspects of electricity.



Italian Case I

Lezione 15

Chiara Foglietta

Definition of Power
Grid

Historical Notes

Structure of the Power
System

Generating Units

Substations

Transmission and
Distribution Network

Energy Management
System

State Estimation

Automatic Generation
Control

9

1883: in Milan, the first power plant was built to power the illumination of Scala Theatre.

1904: The first geothermal power station in the world was built in Larderello, Tuscany.

1962: The electricity sector, private until then, was nationalized with the creation of the state-controlled entity named ENEL, with the monopoly on production, transmission and distribution of electric energy.



Italian Case II

Lezione 15

Chiara Foglietta

Definition of Power Grid

Historical Notes

Structure of the Power System

Generating Units

Substations

Transmission and Distribution Network

Energy Management System

State Estimation

Automatic Generation Control

10

1992: ENEL was made a joint-stock company, however still owned by the Ministry of Economy, following European directives. It was based on the adoption of different regulations for production and transmission: production and trading should be free and managed by private companies, while transmission and distribution, being natural monopolies, should be regulated by the state.

1999: the Italian legislative decree 79/1999 ("Decreto Bersani") created a path towards a complete liberalization of the market through gradual steps.



Italian Case III

Lezione 15

Chiara Foglietta

Definition of Power Grid

Historical Notes

Structure of the Power System

Generating Units

Substations

Transmission and Distribution Network

Energy Management System

State Estimation

Automatic Generation Control

11

1999: The network was transferred to a new company, Terna, responsible for the management of the system. Moreover, the limit on Enel property share of Terna was set at 20%. ENEL eventually sold its remaining share of the company in January 2012.

In order to improve competition and to develop a free market for production, Enel was also forced to sell 15,000 MW of capacity to competitors before 2003. Following this, three new production companies were created: Endesa Italia, Edipower and Tirreno Power. A new European directive, 2003/54/CE of 2003, and a subsequent Italian decree, requested a free electricity trading for all commercial clients from July 2004 and, eventually, a complete opening of the market for private customers from July 2007.

Lezione 15

Chiara Foglietta

Definition of Power Grid

Historical Notes

Structure of the Power System

Generating Units

Substations

Transmission and Distribution Network

Energy Management System

State Estimation

Automatic Generation Control

12

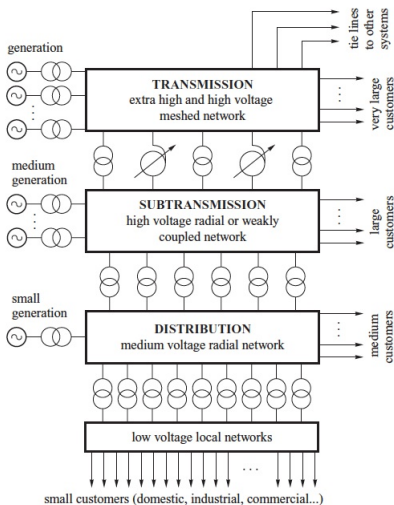



Generation

Lezione 15

Chiara Foglietta

Definition of Power Grid

Historical Notes

Structure of the Power System

Generating Units

Substations

Transmission and Distribution Network

Energy Management System

State Estimation

Automatic Generation Control

13

Traditionally power system operation has been based around a relatively small number of large power plants connected to the transmission system. Those plants are usually thermal or hydro plants in which electricity is produced by converting the mechanical energy appearing on the output shaft of an engine, or more usually a turbine, into electrical energy. The main thermal energy resources used commercially are coal, natural gas, nuclear fuel and oil.

The conversion of mechanical to electrical energy in traditional thermal or hydro plants is almost universally achieved by the use of a synchronous generator. The synchronous generator feeds its electrical power into the transmission system via a step-up transformer.

56



Renewable Resources

Lezione 15

Chiara Foglietta

Definition of Power
Grid

Historical Notes

Structure of the Power
System

Generating Units
Substations
Transmission and
Distribution Network

Energy Management
System

State Estimation

Automatic Generation
Control

14

Generally there are three main ways the industry can reduce its CO₂ emissions:

1. by moving from the traditional coal/gas/oil-based generation to renewable generation (wind, solar, marine);
2. by moving towards increased nuclear generation which is largely CO₂-free;
3. by removing CO₂ from exhaust gases of traditional thermal generation using for example carbon capture and storage technology.

Lezione 15

Chiara Foglietta

Definition of Power Grid

Historical Notes

Structure of the Power System

Generating Units

Substations

Transmission and Distribution Network

Energy Management System

State Estimation

Automatic Generation Control

15

Since the energy lost in a transmission line is proportional to the current squared, transmission lines operate at high or very high voltages. The electrical network connects all the power stations into one system, and transmits and distributes power to the load centres in an optimal way. Usually the transmission network has a mesh structure in order to provide many possible routes for electrical power to flow from individual generators to individual consumers thereby improving the flexibility and reliability of the system.

The transmission network makes the power system a highly interacting, complicated mechanism, in which an action of any individual component (a power plant or a load) influences all the other components in the system. This is the main reason why transmission remains a monopoly business, even under the liberalized market structure, and is managed by a single system operator.



Distribution

Lezione 15

Chiara Foglietta

Definition of Power Grid

Historical Notes

Structure of the Power System

Generating Units

Substations

Transmission and Distribution Network

Energy Management System

State Estimation

Automatic Generation Control

16

Most of the electrical energy is transferred from the transmission, or subtransmission, network to distribution high-voltage and medium-voltage networks in order to bring it directly to the consumer. The distribution network is generally connected in a radial structure as opposed to the mesh structure used in the transmission system. Large consumers may be supplied from a weakly coupled, meshed, distribution network or, alternatively, they may be supplied from two radial feeders with a possibility of automatic switching between feeders in case of a power cut. Some industrial consumers may have their own on-site generation as a reserve or as a by-product of a technological process (e.g. steam generation). Ultimately power is transformed to a low voltage and distributed directly to consumers.



Bidirectional Distribution

Lezione 15

Chiara Foglietta

Definition of Power
Grid

Historical Notes

Structure of the Power
System

Generating Units
Substations
Transmission and
Distribution Network

Energy Management
System

State Estimation

Automatic Generation
Control

17

Power flows in distribution networks may no longer be unidirectional, that is from the point of connection with the transmission network down to customers. In many cases the flows may reverse direction when the wind is strong and wind generation high, with distribution networks even becoming net exporters of power. That situation has created many technical problems with respect to settings of protection systems, voltage drops, congestion management and so on.

56



Demand

Lezione 15

Chiara Foglietta

Definition of Power Grid

Historical Notes

Structure of the Power System

Generating Units

Substations

Transmission and Distribution Network

Energy Management System

State Estimation

Automatic Generation Control

18

The demand for electrical power is never constant and changes continuously throughout the day and night. The changes in demand of individual consumers may be fast and frequent, but as one moves up the power system structure from individual consumers, through the distribution network, to the transmission level, the changes in demand become smaller and smoother as individual demands are aggregated. Consequently the total power demand at the transmission level changes in a more or less predictable way that depends on the season, weather conditions, way of life of a particular society and so on. Fast global power demand changes on the generation level are usually small and are referred to as load fluctuations.

56

Lezione 15

Chiara Foglietta

Definition of Power Grid

Historical Notes

Structure of the Power System

Generating Units

Substations

Transmission and Distribution Network

Energy Management System

State Estimation

Automatic Generation Control

19

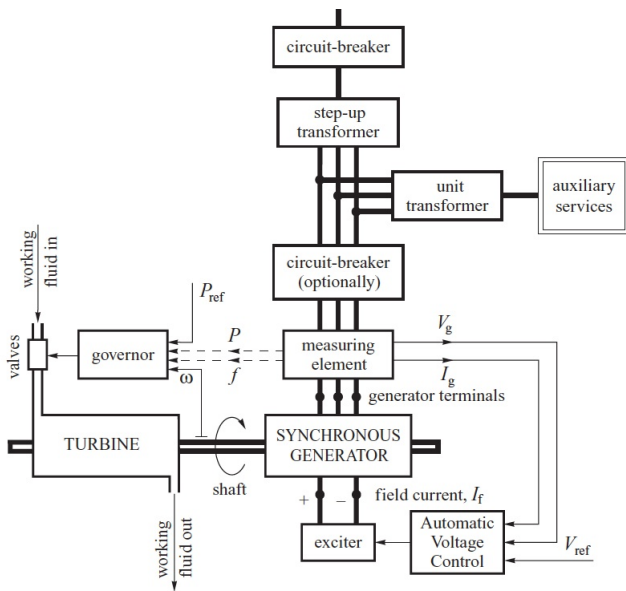

Lezione 15

Chiara Foglietta

Definition of Power
Grid

Historical Notes

Structure of the Power
System

Generating Units

Substations

Transmission and
Distribution Network

Energy Management
System

State Estimation

Automatic Generation
Control

20

Electrical energy is produced by a synchronous generator driven by a prime mover, usually a turbine or a diesel engine. The turbine is equipped with a *turbine governor* which controls either the speed or the output power according to a preset power–frequency characteristic.

The generated power is fed into the transmission network via a step-up transformer. The DC excitation (or field) current, required to produce the magnetic field inside the generator, is provided by the *exciter*.

The excitation current, and consequently the generator's terminal voltage, is controlled by an *automatic voltage regulator* (AVR). An additional *unit transformer* may be connected to the busbar between the generator and the step-up transformer in order to supply the power station's auxiliary services comprising motors, pumps, the exciter and so on.

56



Generating Units II

Lezione 15

Chiara Foglietta

Definition of Power
Grid

Historical Notes

Structure of the Power
System

Generating Units

Substations

Transmission and
Distribution Network

Energy Management
System

State Estimation

Automatic Generation
Control

21

The generating unit is equipped with a main *circuit-breaker* on the high-voltage side and sometimes also with a *generator circuit-breaker* on the generator side. Such a configuration is quite convenient because, in case of a maintenance outage or a fault, the generator circuit-breaker may be opened while the auxiliary services can be fed from the grid. On the other hand, with the main circuit-breaker open, the generator may supply its own auxiliary services.

56



Substations

Lezione 15

Chiara Foglietta

Definition of Power
Grid

Historical Notes

Structure of the Power
System

Generating Units

Substations

Transmission and
Distribution Network

Energy Management
System

State Estimation

Automatic Generation
Control

22

A substation can be regarded as a point of electrical connection where the transmission lines, transformers, generating units, system monitoring and control equipment are connected together.

Consequently, it is at substations that the flow of electrical power is controlled, voltages are transformed from one level to another and system security is provided by automatic protective devices.

These incoming and outgoing circuits are connected to a common busbar system and are equipped with apparatus to switch electrical currents, conduct measurements and protect against lightning.



Transmission and Distribution Network

Lezione 15

Chiara Foglietta

Definition of Power
Grid

Historical Notes

Structure of the Power
System

Generating Units

Substations

Transmission and
Distribution Network

Energy Management
System

State Estimation

Automatic Generation
Control

23

The transmission and distribution network connects all the power stations into one supplying system and transmits and distributes power to individual consumers.

The basic elements of the network are the overhead power lines, underground cables, transformers and substations.

Auxiliary elements are the series reactors, shunt reactors and compensators, switching elements, metering elements and protection equipment.

56



Lines and Cables

Lezione 15

Chiara Foglietta

Definition of Power Grid

Historical Notes

Structure of the Power System

Generating Units

Substations

Transmission and Distribution Network

Energy Management System

State Estimation

Automatic Generation Control

24

Overhead lines are universally used to transmit electrical energy in high-voltage transmission systems while underground cables are normally only used in low- and medium-voltage urban distribution networks.

For practical reasons there is a standardization of voltage levels within different regions of the world. Unfortunately these standard voltages tend to vary slightly between regions but are not too dissimilar. Typical transmission voltage levels are 110, 220, 400, 750 kV for Continental Europe, 132, 275, 400 kV for the United Kingdom and 115, 230, 345, 500, 765 kV for the United States.

Distribution networks generally operate at lower voltages than the transmission network. For example, there are 12 different standard distribution voltages in the United States, in the range between 2.4 and 69 kV. In the United Kingdom the distribution voltages are 6.6, 11, 33 and 66 kV.

56



Transformers

Lezione 15

Chiara Foglietta

Definition of Power Grid

Historical Notes

Structure of the Power System

Generating Units

Substations

Transmission and Distribution Network

Energy Management System

State Estimation

Automatic Generation Control

25

Transformers are necessary to link parts of the power systems that operate at different voltage levels. In addition to changing voltage levels, transformers are also used to control voltage and are almost invariably equipped with taps on one or more windings to allow the turns ratio to be changed.

Power system transformers can be classified by their function into three general categories:

- ▶ generator step-up transformers (which connect the generator to the transmission network) and unit transformers (which supply the auxiliary service);
- ▶ transmission transformers, which are used to connect different parts of the transmission network, usually at different voltage levels, or connect the transmission and distribution networks;
- ▶ distribution transformers, which reduce the voltage at load centres to a low voltage level required by the consumer.

56

Lezione 15

Chiara Foglietta

Definition of Power
Grid

Historical Notes

Structure of the Power
System

Generating Units

Substations

Transmission and
Distribution Network

26

Energy Management
System

State Estimation

Automatic Generation
Control

Controlling the voltage transformation ratio without phase shift control is used for generator step-up transformers as well as for transmission and distribution transformers. The easiest way to achieve this task is by using tap changers to change the transformation ratio.

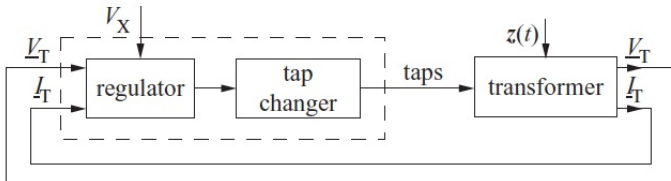



Shunt Elements

Lezione 15

Chiara Foglietta

Definition of Power Grid

Historical Notes

Structure of the Power System

Generating Units

Substations

Transmission and Distribution Network

Energy Management System

State Estimation

Automatic Generation Control

27

Generally, reactive power cannot be transmitted over long distances and should be compensated for close to the point of consumption. The simplest, and cheapest, way of achieving this is by providing shunt compensation, that is by installing capacitors and/or inductors connected either directly to a busbar or to the tertiary winding of a transformer.

Shunt elements may also be located along the transmission route to minimize losses and voltage drops. Traditionally, static shunt elements are breaker switched either manually or automatically by a voltage relay.

56



Series Elements

Lezione 15

Chiara Foglietta

Definition of Power
Grid

Historical Notes

Structure of the Power
System

Generating Units

Substations

Transmission and
Distribution Network

Energy Management
System

State Estimation

Automatic Generation
Control

28

Series capacitors are connected in series with transmission line conductors in order to offset the inductive reactance of the line. This tends to improve electromechanical and voltage stability, limit voltage dips at network nodes and minimize the real and reactive power loss.

Normally series capacitors are located either at the line terminals or at the middle of the line. Although fault currents are lower, and line protection easier, when the capacitors are located at the mid-point, the access necessary for maintenance, control and monitoring is significantly eased if the capacitor banks are positioned at the line terminals.

56

Lezione 15

Chiara Foglietta

Definition of Power Grid

Historical Notes

Structure of the Power System

Generating Units

Substations

Transmission and Distribution Network

Energy Management System

29

State Estimation

Automatic Generation Control

The main goal of the system operator is to maintain the system in the normal secure state as the operating conditions vary during the daily operation. Accomplishing this goal requires continuous monitoring of the system conditions, identification of the operating state and determination of the necessary preventive actions in case the system state is found to be *insecure*. This sequence of actions is referred to as the security analysis of the system.

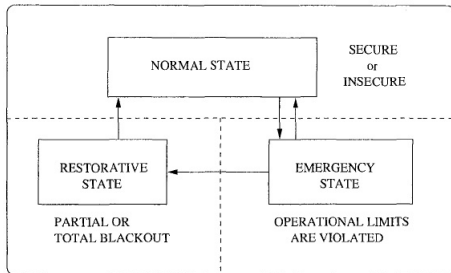

Lezione 15

Chiara Foglietta

Definition of Power
Grid

Historical Notes

Structure of the Power
System

Generating Units

Substations

Transmission and
Distribution Network

Energy Management
System

30

State Estimation

Automatic Generation
Control

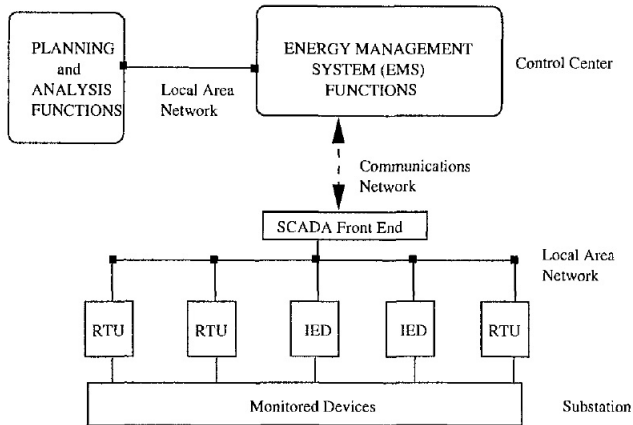



EMS Primary Functions I

Lezione 15

Chiara Foglietta

Definition of Power
Grid

Historical Notes

Structure of the Power
System

Generating Units

Substations

Transmission and
Distribution Network

Energy Management
System

31

State Estimation

Automatic Generation
Control

1. Network Configuration / Topology Processor
2. State Estimation
3. Contingency Analysis
4. Three Phase Balanced Operator Power Flow
5. Optimal Power Flow
6. Dispatcher Training Simulator



EMS Primary Functions II

Lezione 15

Chiara Foglietta

Definition of Power Grid

Historical Notes

Structure of the Power System

Generating Units

Substations

Transmission and Distribution Network

Energy Management System

32

State Estimation

Automatic Generation Control

1. System Load Forecast: Every hour for a period of 1-7 days
2. Start up and shut down times for most economic operation of thermal units for each hour
3. Fuel Scheduling: Economic choice, fuel purchase contract
4. Transaction Evaluation: Purchase and sale of energy with neighbouring companies
5. Transmission loss minimization: Controller actions for minimization of loss
6. Security Constrained Dispatch: Ensuring economic dispatch without violating network security
7. Production cost calculation: Actual and economical for each generated unit on hourly basis

Lezione 15

Chiara Foglietta

Definition of Power Grid

Historical Notes

Structure of the Power System

Generating Units

Substations

Transmission and Distribution Network

Energy Management System

33

State Estimation

Automatic Generation Control

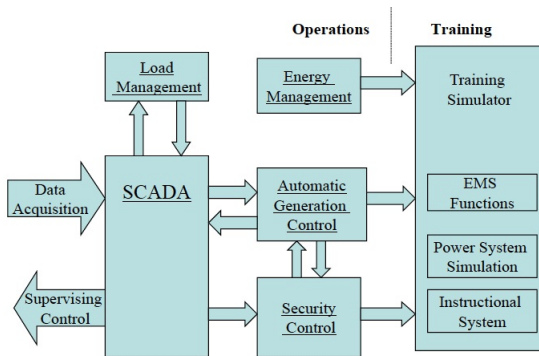

Lezione 15

Chiara Foglietta

Definition of Power
Grid

Historical Notes

Structure of the Power
System

Generating Units

Substations

Transmission and
Distribution Network

Energy Management
System

34

State Estimation

Automatic Generation
Control

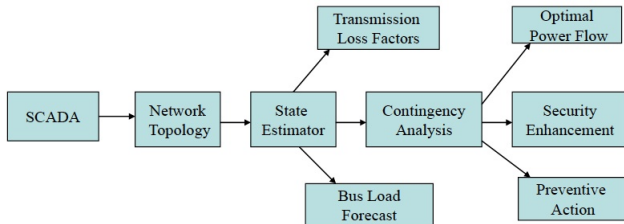



Real-Time Analysis Sequence II

Lezione 15

Chiara Foglietta

Definition of Power Grid

Historical Notes

Structure of the Power System

Generating Units

Substations

Transmission and Distribution Network

Energy Management System

35

State Estimation

Automatic Generation Control

- ▶ Contingency: Event that causes important component to be removed from service. A list of contingency are processed as applicable to current state
- ▶ Topology Processing: Building a network model based on real-time measurements
- ▶ State Estimator: Determining "best" estimate from real-time measurements
- ▶ Power Flow: Load flow analysis
- ▶ Contingency Analysis: Impact of a set of contingencies to identify harmful ones
- ▶ Optimal Power Flow: Optimization of a specified objective function with constraints
- ▶ Preventive Action: to prevent contingency
- ▶ Short Circuit Analysis: Determines the fault current and locations across the power network

56



State Estimation

Lezione 15

Chiara Foglietta

Definition of Power Grid

Historical Notes

Structure of the Power System

Generating Units

Substations

Transmission and Distribution Network

Energy Management System

State Estimation

Automatic Generation Control

36

In order to identify the current operating state of the system, state estimators facilitate accurate and efficient monitoring of operational constraints on quantities such as the transmission line loadings or bus voltage magnitudes. They provide a reliable real-time data base of the system, including the existing state based on which, security assessment functions can be reliably deployed in order to analyse contingencies, and to determine any required corrective actions.

Power system state estimator constitutes the core of the on-line security analysis function. It acts like a filter between the raw measurements received from the system and all the application functions that require the most reliable data base for the current state of the system.

56



State Estimation Functions I

Lezione 15

Chiara Foglietta

Definition of Power Grid

Historical Notes

Structure of the Power System

Generating Units

Substations

Transmission and Distribution Network

Energy Management System

State Estimation

Automatic Generation Control

37

- ▶ **Topology processor:** Gathers status data about the circuit breakers and switches, and configures the one-line diagram of the system.
- ▶ **Observability analysis:** Determines if a state estimation solution for the entire system can be obtained using the available set of measurements. Identifies the unobservable branches, and the observable islands in the system if any exist.
- ▶ **State estimation solution:** Determines the optimal estimate for the system state, which is composed of complex bus voltages in the entire power system, based on the network model and the gathered measurements from the system. Also provides the best estimates for all the line flows, loads, transformer taps, and generator outputs.

56



State Estimation Functions II

Lezione 15

Chiara Foglietta

Definition of Power Grid

Historical Notes

Structure of the Power System

Generating Units

Substations

Transmission and Distribution Network

Energy Management System

State Estimation

Automatic Generation Control

38

- ▶ Bad data processing: Detects the existence of gross errors in the measurement set. Identifies and eliminates bad measurements provided that there is enough redundancy in the measurement configuration.
- ▶ Parameter and structural error processing: Estimates various network parameters, such as transmission line model parameters, tap changing transformer parameters, shunt capacitor or reactor parameters. Detects structural errors in the network configuration and identifies the erroneous breaker status provided that there is enough measurement redundancy.

56

Lezione 15

Chiara Foglietta

Definition of Power Grid

Historical Notes

Structure of the Power System

Generating Units

Substations

Transmission and Distribution Network

Energy Management System

State Estimation

Automatic Generation Control

39

The phase angle of the reference bus equals zero. The state estimation problem is therefore to estimate the n phase angle state variables $x = (x_1, x_2, \dots, x_n)'$ based on the m active power measurements $z = (z_1, z_2, \dots, z_m)'$, where

$$z = h(x) + e \quad (1)$$

Where h is the vector of functions, usually non-linear, relating error free measurements to the state variables; $e = (e_1, e_2, \dots, e_m)'$ $\sim \mathcal{N}(\mathbf{0}, R)$ is independent measurement noise, where R is the diagonal covariance matrix. The matrix H represents the topology of the considered power grid. In a static context, more measurements are taken into account than the number of state variables to be determined, i.e. $m > n$. In this case, the set of equations 1 represents an overdetermined set of non linear equations.

56

Lezione 15

Chiara Foglietta

Definition of Power
Grid

Historical Notes

Structure of the Power
System

Generating Units

Substations

Transmission and
Distribution Network

Energy Management
System

State Estimation

Automatic Generation
Control

40

The following assumptions are commonly made, regarding the statistical properties of the measurement errors:

1. $\mathbb{E}(\mathbf{e}) = \mathbf{0}$;
2. measurement errors are independent, i.e. $\mathbb{E}(e_i e_j) = 0$.
Hence $\text{cov}(\mathbf{e}) = \mathbb{E}[\mathbf{e} \cdot \mathbf{e}^T] = \mathbf{R} \text{diag} \{ \sigma_1^2, \sigma_2^2, \dots, \sigma_m^2 \}$

The standard deviation σ_i of each measurement i is calculated to reflect the expected accuracy of the corresponding meter used.

56

Lezione 15

Chiara Foglietta

Definition of Power

Grid

Historical Notes

Structure of the Power
System

Generating Units

Substations

Transmission and
Distribution Network

Energy Management
System

State Estimation

Automatic Generation
Control

41

The state estimation problem can be solved as an unconstrained weighted least-squares (WLS) problem. The WLS estimator minimizes the weighted sum of the squares of the residuals, expressed as

$$\begin{aligned} J(x) &= \sum_{i=1}^m \frac{(z_i - h_i(x))^2}{W_{ii}} \\ &= [z - h(x)]^T R^{-1} [z - h(x)] \end{aligned} \quad (2)$$

where $R = \text{diag}(R_i)$ is the weighting matrix.

At the minimum, the first-order optimality conditions must be satisfied. This can be expressed as:

$$g(x) = \frac{\partial J(x)}{\partial x} = -H^T(x) R^{-1} [z - h(x)] = 0 \quad (3)$$

H is the $m \times n$ measurement Jacobian matrix.

56

Weighted Least-Squares Problem II

Lezione 15

Chiara Foglietta

Definition of Power
Grid

Historical Notes

Structure of the Power
System

Generating Units

Substations

Transmission and
Distribution Network

Energy Management
System

State Estimation

Automatic Generation
Control

42

The first order necessary condition for a minimum are that

$$\frac{\partial J(x)}{\partial x} = -H(x)^T R^{-1} [z - h(x)] = 0 \quad (4)$$

Expanding the nonlinear function $g(x)$ into its Taylor series around the state vector x^k yields:

$$\begin{aligned} g(x) &\cong g(x^k) + G(x^k)(x - x^k) = g(x^k) + G(x^k)\Delta x^{k+1} = 0 \\ G(x^k)x &= G(x^k)x^k - g(x^k) \\ x &= x^k - [G(x^k)]^{-1} g(x^k) \end{aligned} \quad (5)$$

where k is the iterative index; x^k is the solution vector at iteration k . The matrix $G(x^k)$ is called *gain matrix* and it is calculated as

$$G(x^k) = \frac{\partial g(x^k)}{\partial x} = H^T(x^k)R^{-1}H(x^k) \quad (6)$$

56

Lezione 15

Chiara Foglietta

Definition of Power
Grid

Historical Notes

Structure of the Power
System

Generating Units

Substations

Transmission and
Distribution Network

Energy Management
System

State Estimation

Automatic Generation
Control

43

The gain matrix is sparse, positive definite and symmetric provided that the system is fully observable. The matrix $G(x)$ is typically not inverted, but instead it is decomposed into its triangular factors and the following sparse linear set of equations are solved using forward/back substitutions at each iteration k :

$$G(x^k)\Delta x^{k+1} = H^T(x^k)R^{-1} [z - h(x_k)] \quad (7)$$

where $\Delta x^{k+1} = x^{k+1} - x^k$. This equation is also referred to as the Normal Equations. Iterations are terminated when an appropriate tolerance is reached on Δx_k .

56



Automatic Generation Control I

Lezione 15

Chiara Foglietta

Definition of Power Grid

Historical Notes

Structure of the Power System

Generating Units

Substations

Transmission and Distribution Network

Energy Management System

State Estimation

Automatic Generation Control

44

The large, slow changes in demand are met centrally by deciding at regular intervals which generating units will be operating, shut down or in an intermediate hot reserve state. This process of unit commitment may be conducted once per day to give the daily operating schedule, while at shorter intervals, typically every 30min, economic dispatch determines the actual power output required from each of the committed generators.

56



Automatic Generation Control II

Lezione 15

Chiara Foglietta

Definition of Power Grid

Historical Notes

Structure of the Power System

Generating Units

Substations

Transmission and Distribution Network

Energy Management System

State Estimation

Automatic Generation Control

45

Smaller, but faster, load changes are dealt with by AGC so as to:

- ▶ maintain frequency at the scheduled value (frequency control);
- ▶ maintain the net power interchanges with neighbouring control areas at their scheduled values (tie-line control);
- ▶ maintain power allocation among the units in accordance with area dispatching needs (energy market, security or emergency).

56



Primary Control I

Lezione 15

Chiara Foglietta

Definition of Power
Grid

Historical Notes

Structure of the Power
System

Generating Units

Substations

Transmission and
Distribution Network

Energy Management
System

State Estimation

Automatic Generation
Control

46

When the total generation is equal to the total system demand (including losses) then the frequency is constant, the system is in equilibrium, and the generation characteristic is approximated by

$$\frac{\Delta f}{f_n} = -\rho_T \frac{\Delta P_T}{P_L} \quad (8)$$

where ρ_T is the local speed droop of the generation characteristic and depends on the spinning reserve and its allocation in the system.

56

Lezione 15

Chiara Foglietta

Definition of Power
Grid

Historical Notes

Structure of the Power
System

Generating Units

Substations

Transmission and
Distribution Network

Energy Management
System

State Estimation

Automatic Generation
Control

47

System loads are also frequency dependent and an expression similar to previous one) can be used to obtain a linear approximation of the frequency response characteristic of the total system load as

$$\frac{\Delta P_L}{P_L} = K_L \frac{\Delta f}{f_n} \quad (9)$$

where K_L is the frequency sensitivity coefficient of the power demand.

56



Primary Control III

Lezione 15

Chiara Foglietta

Definition of Power Grid

Historical Notes

Structure of the Power System

Generating Units

Substations

Transmission and Distribution Network

Energy Management System

State Estimation

Automatic Generation Control

48

In the (P, f) plane the intersection of the generation and the load characteristic defines the system equilibrium point. A change in the total power demand ΔP_L corresponds to a shift of the load characteristic.

The increase in the system load is compensated in two ways: firstly, by the turbines increasing the generation by ΔP_T ; and secondly, by the system loads reducing the demand by ΔP_L .

56



Secondary Control I

Lezione 15

Chiara Foglietta

Definition of Power Grid

Historical Notes

Structure of the Power System

Generating Units

Substations

Transmission and Distribution Network

Energy Management System

State Estimation

Automatic Generation Control

49

If the turbine-generators are equipped with governing systems, then, following a change in the total power demand, the system will not be able to return to the initial frequency on its own, without any additional action.

In order to return to the initial frequency the generation characteristic must be shifted. Such a shift can be enforced by changing the P_{ref} setting in the turbine governing system, the load reference set point. Changing more settings P_{ref} of individual governors will move upwards the overall generation characteristic of the system. Eventually this will lead to the restoration of the rated frequency but now at the required increased value of power demand. Such control action on the governing systems of individual turbines is referred to as secondary control.

56

Secondary Control II

Lezione 15

Chiara Foglietta

Definition of Power
Grid

Historical Notes

Structure of the Power
System

Generating Units

Substations

Transmission and
Distribution Network

Energy Management
System

State Estimation

Automatic Generation
Control

50

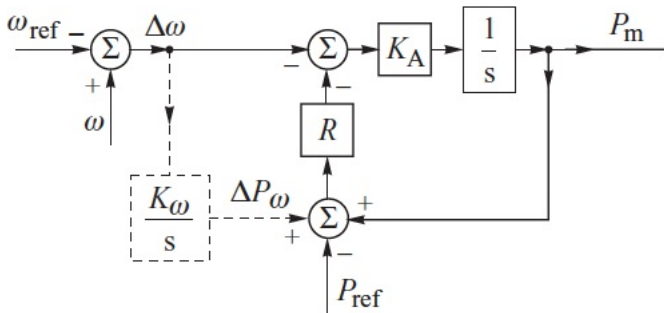

56

Lezione 15

Chiara Foglietta

Definition of Power
Grid

Historical Notes

Structure of the Power
System

Generating Units

Substations

Transmission and
Distribution Network

Energy Management
System

State Estimation

Automatic Generation
Control

51

In an isolated power system, automatic secondary control may be implemented as a decentralized control function by adding a supplementary control loop to the turbine–governor system. This modifies the block diagram of the turbine governor where P_{ref} and P_m are expressed as a fraction of the rated power P_n . The supplementary control loop, consists of an integrating element which adds a control signal ΔP_ω that is proportional to the integral of the speed (or frequency) error to the load reference point. This signal modifies the value of the setting in the P_{ref} circuit thereby shifting the speed–droop characteristic.

56

Lezione 15

Chiara Foglietta

Definition of Power Grid

Historical Notes

Structure of the Power System

Generating Units
Substations
Transmission and Distribution Network

Energy Management System

State Estimation

Automatic Generation Control

52

In an interconnected power system consisting of a number of different control areas, secondary control cannot be decentralized because the supplementary control loops have no information as to where the power imbalance occurs so that a change in the power demand in one area would result in regulator action in all the other areas. Such decentralized control action would cause undesirable changes in the power flows in the tie-lines linking the systems and the consequent violation of the contracts between the cooperating systems. To avoid this, centralized secondary control is used. In interconnected power systems, AGC is implemented in such away that each area, or subsystem, has its own central regulator. The power system is in equilibrium if, for each area, the total power generation P_T , the total power demand P_L and the net tie-line interchange power P_{tie} satisfy the condition:

$$P_T - (P_L + P_{tie}) = 0 \quad (10)$$

Lezione 15

Chiara Foglietta

Definition of Power
Grid

Historical Notes

Structure of the Power
System

Generating Units

Substations

Transmission and
Distribution Network

Energy Management
System

State Estimation

Automatic Generation
Control

53

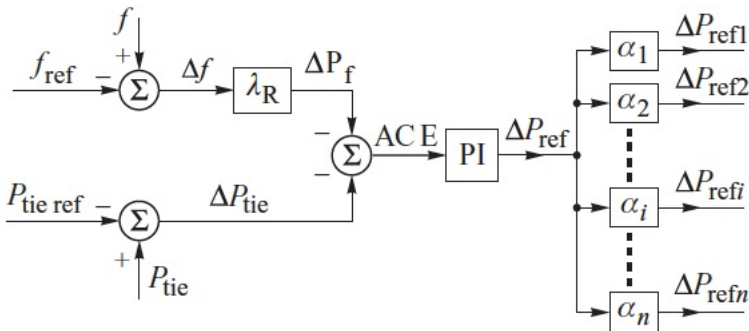

56

Lezione 15

Chiara Foglietta

Definition of Power
Grid

Historical Notes

Structure of the Power
System

Generating Units

Substations

Transmission and
Distribution Network

Energy Management
System

State Estimation

Automatic Generation
Control

54

The *area control error* (ACE) is defined as

$$ACE = -\Delta P_{tie} - \lambda_R \Delta f \quad (11)$$

The choice of the bias factor λ_R plays an important role in the non-intervention rule.

The central regulator must have an integrating element in order to remove any error and this may be supplemented by a proportional element. For such a PI regulator the output signal is:

$$\Delta P_{ref} = \beta_R (ACE) + \frac{1}{T_R} \int_0^t (ACE) dt \quad (12)$$

where β_R and T_R are the regulator parameters.

56

AGC as a Multi-Level Control

Lezione 15

Chiara Foglietta

Definition of Power Grid

Historical Notes

Structure of the Power System

Generating Units

Substations

Transmission and Distribution Network

Energy Management System

State Estimation

Automatic Generation Control

55

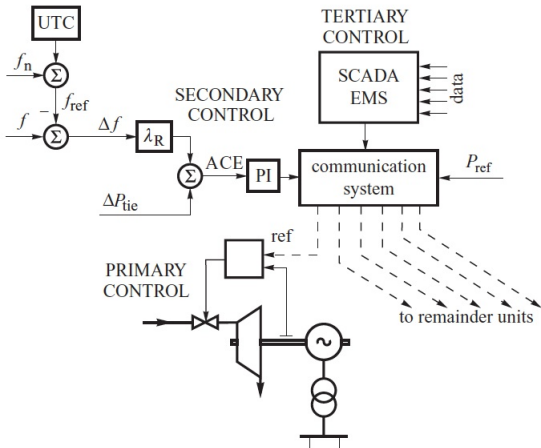

56



Conclusion

Lezione 15

Chiara Foglietta

Definition of Power
Grid

Historical Notes

Structure of the Power
System

Generating Units

Substations

Transmission and
Distribution Network

Energy Management
System

State Estimation

Automatic Generation
Control

56

In this lesson we see the history of the power grid, with particular attention to the Italian case. We are take a look at power operations and its main devices.

Then we define the Energy Management System functionality, with a special focus on the state estimation and on generation control.

56